



Einfach. Sicher.



LEISTUNGSERKLÄRUNG

Nr. 0043 – DE

1. Eindeutiger Kenncode des Produkttyps: **Upat Ankerbolzen MAX**

2. Verwendungszweck(e):

Produkt	Verwendungszweck (e)
Metalldübel zur Verwendung im Beton (hoch belastbar)	Zur Verankerung und/oder Unterstützung tragender Betonelemente oder schwerer Bauteile wie Bekleidungen und Unterdecken , siehe Anhang, insbesondere Anhänge B 1 bis B 4

3. Hersteller: **Upat Vertriebs GmbH, Otto-Hahn-Straße 15, 79211 Denzlingen, Deutschland**

4. Bevollmächtigter: --

5. System(e) zur Bewertung und Überprüfung der Leistungsbeständigkeit: **1**

6a. Harmonisierte Norm: ---

Notifizierte Stelle(n): ---

6b. Europäisches Bewertungsdokument: **ETAG 001; 2013-04**

Europäische Technische Bewertung: **ETA-10/0170; 2015-05-07**

Technische Bewertungsstelle: **DIBt**

Notifizierte Stelle(n): **1343 – MPA Darmstadt**

7. Erklärte Leistung(en):

Mechanische Festigkeit und Standsicherheit (BWR 1)

Wesentliches Merkmal	Leistung
Charakteristischer Widerstand für statische und quasistatische Einwirkungen für die Bemessung nach ETAG 001 Anhang C oder CEN/TS 1992-4:2009	Siehe Anhang, insbesondere Anhänge C 1 bis C 3
Charakteristischer Widerstand für die seismische Leistungskategorien C1 und C2	Siehe Anhang, insbesondere Anhänge C 6 bis C 7
Verschiebungen für statische und quasi-statische Einwirkungen	Siehe Anhang, insbesondere Anhang C 8
Verschiebungen für seismische Einwirkungen	Siehe Anhang, insbesondere Anhang C 9

Brandschutz (BWR 2)

Wesentliches Merkmal	Leistung
Brandverhalten	Der Dübel erfüllt die Anforderungen der Klasse A 1
Feuerwiderstand	Siehe Anhang, insbesondere Anhang C 4, C 5

8. Angemessene Technische Dokumentation und/oder Spezifische Technische Dokumentation: ---

Die Leistung des vorstehenden Produkts entspricht der erklärten Leistung/den erklärten Leistungen. Für die Erstellung der Leistungserklärung im Einklang mit der Verordnung (EU) Nr. 305/2011 ist allein der obengenannte Hersteller verantwortlich.

Unterzeichnet für den Hersteller und im Namen des Herstellers von:

Andreas Bucher, Dipl.-Ing.

Wolfgang Hengesbach, Dipl.-Ing., Dipl.-Wirtsch.-Ing.

Tumlingen, 2015-05-18

- Diese Leistungserklärung wurde in verschiedenen Sprachversionen erstellt. Für den Fall unterschiedlicher Auslegung hat immer die englische Version Vorrang.

- Der Anhang enthält freiwillige und ergänzende Informationen in englischer Sprache. Diese gehen über die (sprachneutral angegebenen) gesetzlichen Anforderungen hinaus.

Specific Part**1 Technical description of the product**

The UPAT Anchor bolt MAX is an anchor made of galvanised steel (MAX) or made of stainless steel (MAX A4) or high corrosion resistant steel (MAX C) which is placed into a drilled hole and anchored by torque-controlled expansion.

The product description is given in Annex A.

2 Specification of the intended use in accordance with the applicable European Assessment Document

The performances given in Section 3 are only valid if the anchor is used in compliance with the specifications and conditions given in Annex B.

The verifications and assessment methods on which this European Technical Assessment is based lead to the assumption of a working life of the anchor of at least 50 years. The indications given on the working life cannot be interpreted as a guarantee given by the producer, but are to be regarded only as a means for choosing the right products in relation to the expected economically reasonable working life of the works.

3 Performance of the product and references to the methods used for its assessment**3.1 Mechanical resistance and stability (BWR 1)**

Essential characteristic	Performance
Characteristic resistance for static and quasi static action for design according to ETAG 001 Annex C or CEN/TS 1992-4:2009	See Annex C 1 to C 3
Characteristic resistance for Seismic performance categories C1 and C2	See Annex C 6 to C 7
Displacements under static and quasi static action	See Annex C 8
Displacements under seismic action	See Annex C 9

3.2 Safety in case of fire (BWR 2)

Essential characteristic	Performance
Reaction to fire	Anchorage satisfy requirements for Class A1
Characteristic resistance under fire exposure	See Annex C 4,C 5

3.3 Hygiene, health and the environment (BWR 3)

Not applicable.

3.4 Safety in use (BWR 4)

The essential characteristics regarding Safety in use are included under the Basic Works Requirement Mechanical resistance and stability.

3.5 Protection against noise (BWR 5)

Not applicable.

3.6 Energy economy and heat retention (BWR 6)

Not applicable.

3.7 Sustainable use of natural resources (BWR 7)

The sustainable use of natural resources was not investigated.

3.8 General aspects

The verification of durability is part of testing the essential characteristics. Durability is only ensured if the specifications of intended use according to Annex B are taken into account.

4 Assessment and verification of constancy of performance (AVCP) system applied, with reference to its legal base

According to Decision of the Commission of 24 June 1996 (96/582/EC) (OJ L 254 of 08.10.96 p. 62-65), the system of assessment and verification of constancy of performance (see Annex V and Article 65 Paragraph 2 to Regulation (EU) No 305/2011) given in the following table applies.

Product	Intended use	Level or class	System
Metal anchors for use in concrete (heavy-duty type)	For fixing and/or supporting concrete structural elements or heavy units such as cladding and suspended ceilings	—	1

Cone bolt manufactured by cold – forming:

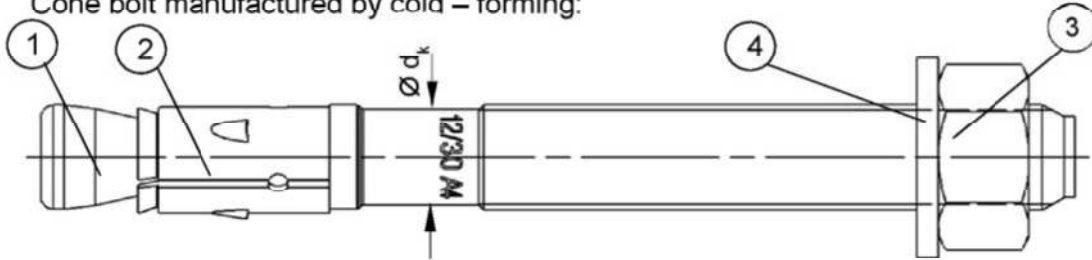

Cone bolt manufactured by turning:

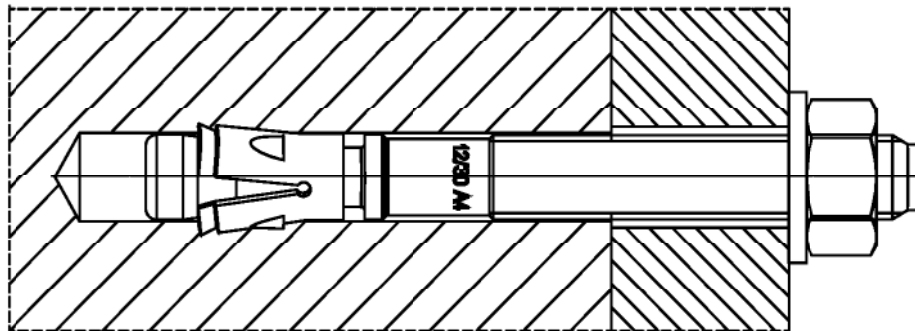
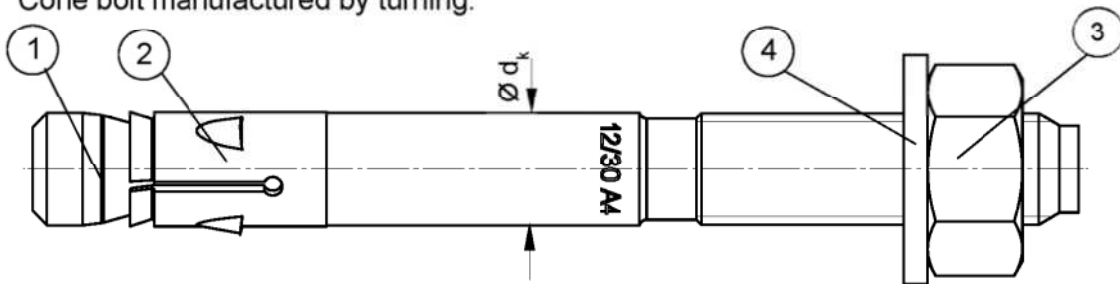

- ① Cone bolt (cold – formed or turned)
- ② Expansion sleeve
- ③ Hexagon nut
- ④ Washer

UPAT Anchor bolt MAX, MAX A4, MAX C

Product description
Installed condition

Annex A 1

MAX for use with standard and reduced anchorage depth ($h_{ef, sta}$ and $h_{ef, red}$):

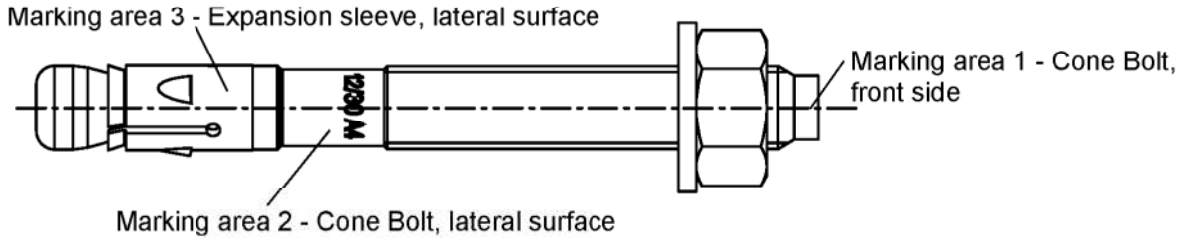

Product label, example:

MAX 12/10 A4

Brand | type of anchor placed on marking area 2 or marking area 3

thread size / max. thickness of fixture (t_{fix}) for $h_{ef, sta}$ identification A4 placed on marking area 2

Table A1: Letter-code on marking area 1 and maximum thickness of fixture t_{fix} :

marking	(A)	(B)	(C)	(D)	(E)	(F)	(G)	(H)	(I)	(K)	(L)	(M)	(N)	(O)	(P)	(R)	(S)	(T)	(U)	(V)	(W)	(X)	(Y)	(Z)	
max. t_{fix} for $h_{ef, sta}$	M8-M24	5	10	15	20	25	30	35	40	45	50	60	70	80	90	100	120	140	160	180	200	250	300	350	400
max. t_{fix} for $h_{ef, red}$	M10-M16	25	30	35	40	45	50	55	60	65	70	80	90	100	110	120	140	160	180	200	220	270	320	370	420

MAX K for use with reduced anchorage depth only ($h_{ef, red}$):

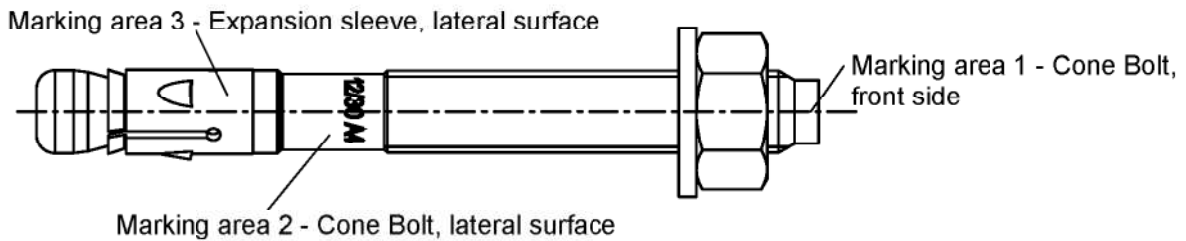

Product label, example:

MAX 12/10 K A4

Brand | type of anchor placed on marking area 2 or marking area 3

thread size / max. thickness of fixture (t_{fix}) identification K for $h_{ef, red}$ | identification A4 placed on marking area 2

Table A2: Letter-code on marking area 1 and maximum thickness of fixture t_{fix} :

marking	(a)	(b)	(c)	(d)	
max. t_{fix} for $h_{ef, red}$	M10-M16	5	10	15	20

Identification for $h_{ef, red}$ are lower-case letters

UPAT Anchor bolt MAX, MAX A4, MAX C

Product description
Anchor Types

Annex A 2

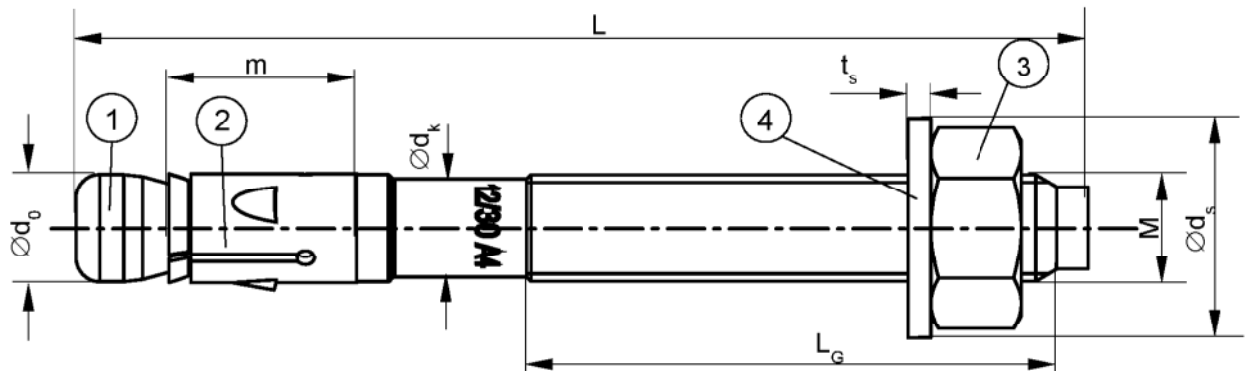

Table A3: Anchor dimensions [mm]

Part	Designation	MAX, MAX A4, MAX C						
		M8	M10	M12	M16	M20	M24	
1	Cone bolt	thread size M	M8	M10	M12	M16	M20	M24
		Ø d ₀	7,8	9,8	11,8	15,7	19,8	23,5
		Ø d _k	7,1	8,9	10,7	14,5	19,8	23,5
		L _e ≥	19	26	31	40	50	57
2	Expansion sleeve	m	17,8	20,0	20,6	27,5	33,4	40,2
		sheet thickness	1,3	1,4	1,6	2,4	2,4	3,0
3	Hexagon nut	wrench size	13	17	19	24	30	36
4	Washer	t _s ≥	1,4	1,8	2,3	2,7	2,7	3,7
		Ø d _s ≥	15	19	23	29	36	43
Thickness of fixture	t _{fix}	≥	0	0	0	0	0	0
		≤	200	250	300	400	500	600
Length of anchor	L _{min}	=	64,5	64,5	79	102	141	174
		L _{max}	=	267	336	401	524,5	644

UPAT Anchor bolt MAX, MAX A4, MAX C

Product description
Anchor dimensions

Annex A 3

Table A4: Materials MAX

Part	Designation	Material
1	Cone bolt	Cold form steel or free cutting steel (zinc plated) Nominal steel tensile strength: $f_{uk} \leq 1000 \text{ N/mm}^2$
2	Expansion sleeve	Cold strip, EN 10139:2013 (zinc plated)
3	Hexagon nut	Steel, property class min. 8, EN ISO 898-2:2012 (zinc plated)
4	Washer	Cold strip, EN 10139:2013 (zinc plated)

Table A5: Materials MAX A4

Part	Designation	Material
1	Cone bolt	stainless steel EN 10088:2014 Nominal steel tensile strength: $f_{uk} \leq 1000 \text{ N/mm}^2$
2	Expansion sleeve	stainless steel EN 10088:2014
3	Hexagon nut	stainless steel EN 10088:2014; ISO 3506-2: 2009; property class – min. 70
4	Washer	stainless steel EN 10088:2014

Table A6: Materials MAX C

Part	Designation	Material
1	Cone bolt	high corrosion resistant steel EN 10088:2014 Nominal steel tensile strength: $f_{uk} \leq 1000 \text{ N/mm}^2$
2	Expansion sleeve	stainless steel EN 10088:2014
3	Hexagon nut	high corrosion resistant steel EN 10088:2014; ISO 3506-2:2009; property class – min. 70
4	Washer	high corrosion resistant steel EN 10088:2014

UPAT Anchor bolt MAX, MAX A4, MAX C

Product description
Materials

Annex A 4

Specifications of intended use

Anchorage subject to:

Standard anchorage depth	✓					
Anchor bolt MAX, MAX A4, MAX C	M8	M10	M12	M16	M20	M24
Static and quasi-static action	✓					
Cracked and non-cracked concrete	✓					
Fire exposure	✓					
Seismic action for Performance Category	C1	✓				
	C2 ¹⁾	-	✓			-
Reduced anchorage depth	-	✓			-	
Anchor bolt MAX, MAX A4, MAX C	-	M10	M12	M16	-	
Static and quasi-static action	-	✓			-	
Cracked and non-cracked concrete	-	✓			-	
Fire exposure	-	✓			-	
Seismic action for Performance Category	C1	-	✓			-
	C2 ¹⁾	-	✓			-

¹⁾ MAX C: Only valid for cold-formed version (see A1)

Base materials:

- Reinforced and unreinforced normal weight concrete (cracked and non-cracked according to EN 206-1:2000).
- Strength classes C20/25 to C50/60 according to EN 206-1:2000

Use conditions (Environmental conditions):

- Structures subject to dry internal conditions (MAX, MAX A4, MAX C).
- Structures subject to external atmospheric exposure (including industrial and marine environment) and to permanently damp internal condition, if no particular aggressive conditions exist. (MAX A4, MAX C).
- Structures subject to external atmospheric exposure and permanently damp internal, if other particular aggressive conditions exist (MAX C).

Note: Particular aggressive conditions are e.g. permanent, alternating immersion in seawater or the splash zone of seawater, chloride atmosphere of indoor swimming pools or atmosphere with extreme chemical pollution (e.g. in desulphurization plants or road tunnels where de-icing materials are used).

Design:

- Anchorages are to be designed under the responsibility of an engineer experienced in anchorages and concrete work.
- Verifiable calculation notes and drawings are to be prepared taking account of the loads to be anchored. The position of the anchor is indicated on the design drawings (e.g. position of the anchor relative to reinforcement or to supports, etc.).
- Anchorages under static or quasi-static actions are to be designed in accordance with (please choose the relevant design method):
 - ETAG 001, Annex C, design method A, Edition August 2010 or
 - CEN/TS 1992-4:2009, design method A
- Anchorages under seismic actions (cracked concrete) are to be designed in accordance with:
 - EOTA Technical Report TR 045, Edition February 2013
 - Anchorages shall be positioned outside of critical regions (e.g. plastic hinges) of the concrete structure.
 - Fastenings in stand-off installation or with a grout layer under seismic action are not allowed.
- Anchorages under fire exposure are to be designed in accordance with:
 - EOTA Technical Report TR 020, Edition May 2004
 - CEN/TS 1992-4:2009, Annex D
 - It must be ensured that local spalling of the concrete cover does not occur.

UPAT Anchor bolt MAX, MAX A4, MAX C

Intended Use
 Specifications

Annex B 1

Table B1: Installation parameters

Type of anchor / size		MAX, MAX A4, MAX C					
		M8	M10	M12	M16	M20	M24
Nominal drill hole diameter	$d_0 = [\text{mm}]$	8	10	12	16	20	24
Cutting diameter of drill bit	$d_{\text{cut}} \leq [\text{mm}]$	8,45	10,45	12,5	16,5	20,55	24,55
Standard anchorage depth	$h_{\text{ef,sta}} \geq [\text{mm}]$	45	60	70	85	100	125
Depth of drill hole in concrete for $h_{\text{ef,sta}}$	$h_{1,\text{sta}} \geq [\text{mm}]$	55	75	90	110	125	155
Reduced anchorage depth	$h_{\text{ef,red}} \geq [\text{mm}]$	-	40	50	65	-	-
Depth of drill hole in concrete for $h_{\text{ef,red}}$	$h_{1,\text{red}} \geq [\text{mm}]$	-	55	70	90	-	-
Diameter of clearance hole in the fixture ¹⁾	$d_f < [\text{mm}]$	9	12	14	18	22	26
Required torque moment	$T_{\text{inst}} = [\text{Nm}]$	20	45	60	110	200	270

¹⁾ If a larger diameter of the clearance hole in the fixture is used, see Chapter 4.2.2.1 of ETAG 001, Annex C

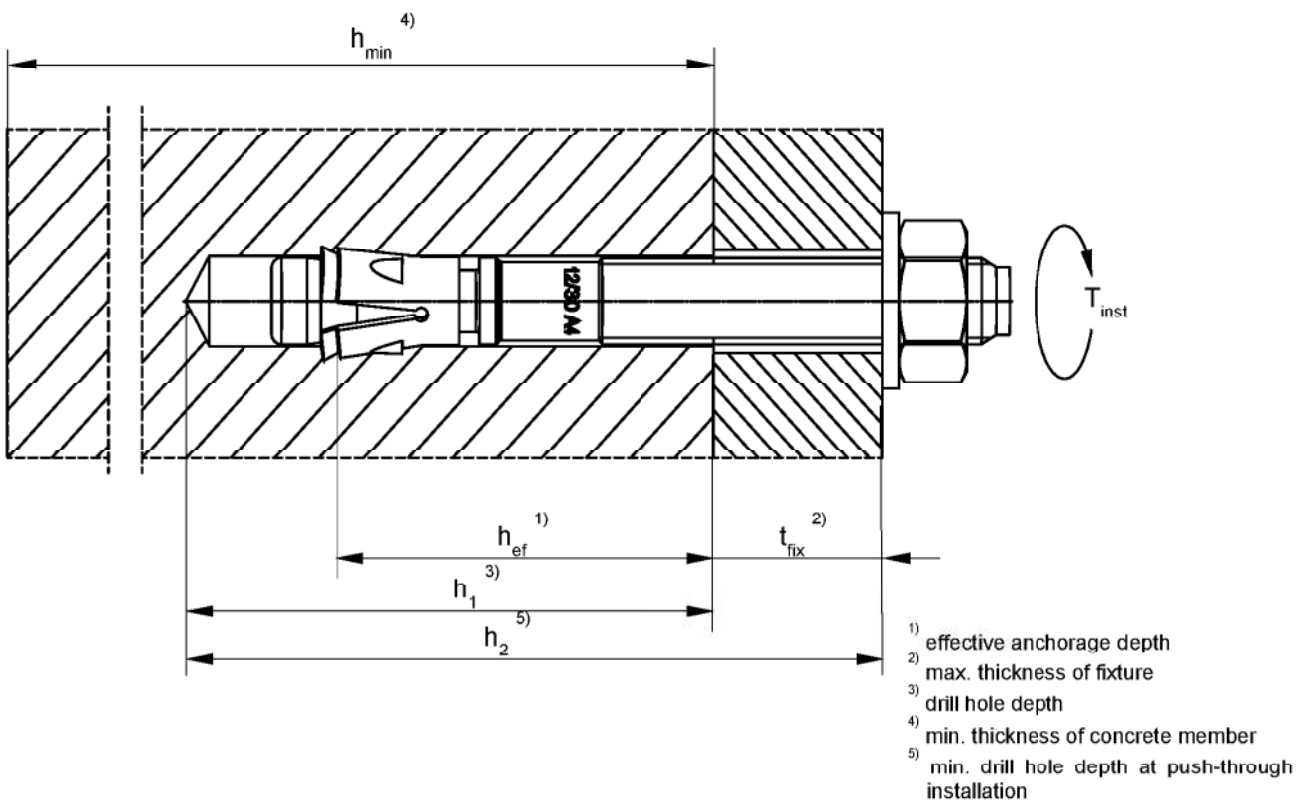

UPAT Anchor bolt MAX, MAX A4, MAX C

Intended Use
 Installation parameters

Annex B 2

Table B2: Minimum thickness of concrete members, minimum spacings and minimum edge distances of anchors for **standard anchorage depth ($h_{ef, sta}$)**

Type of anchor / size		MAX, MAX A4, MAX C						
		M8	M10	M12	M16	M20	M24	
Standard effective anchorage depth	$h_{ef, sta} \geq$ [mm]	45	60	70	85	100	125	
Applications with concrete members of thickness $\geq 2 \times h_{ef}$	Minimum thickness of concrete member	$h_{min, 1}$ [mm]	100	120	140	170	200	250
	Non – cracked concrete							
	Minimum spacing	s_{min} [mm]	40	40	50	65	95	100
		for $c \geq$ [mm]	50	60	70	95	180	200
	Minimum edge distance	c_{min} [mm]	40	45	55	65	95	135
		for $s \geq$ [mm]	100	80	110	150	190	235
	Cracked concrete							
	Minimum spacing	s_{min} [mm]	35	40	50	65	95	100
		for $c \geq$ [mm]	50	55	70	95	140	170
	Minimum edge distance	c_{min} [mm]	40	45	55	65	85	100
for $s \geq$ [mm]		70	80	110	150	190	220	
Applications with concrete members of thickness $< 2 \times h_{ef}$	Minimum thickness of concrete member	$h_{min, 2}$ [mm]	80	100	120	140	160	200
	Cracked and non-cracked concrete							
	Minimum spacing	s_{min} [mm]	35	40	50	80	125	150
		for $c \geq$ [mm]	70	100	90	130	220	230
	Minimum edge distance	c_{min} [mm]	40	60	60	65	125	135
		for $s \geq$ [mm]	100	90	120	180	230	235

Intermediate values for s_{min} and c_{min} inside of the same thickness of concrete member by linear interpolation.

Table B3: Minimum thickness of concrete members, minimum spacings and minimum edge distances of anchors for **reduced anchorage depth ($h_{ef, red}$)**

Type of anchor / size		MAX, MAX A4, MAX C			
		M10	M12	M16	
Reduced effective anchorage depth	$h_{ef, red} \geq$ [mm]	40	50	65	
Applications with concrete members of thickness $\geq 2 \times h_{ef}$	Minimum thickness of concrete member	$h_{min, 3}$ [mm]	80	100	140
	Non – cracked concrete				
	Minimum spacing	s_{min} [mm]	40	50	65
		for $c \geq$ [mm]	100	110	130
	Minimum edge distance	c_{min} [mm]	45	55	65
		for $s \geq$ [mm]	180	220	250
	Cracked concrete				
	Minimum spacing	s_{min} [mm]	40	50	65
		for $c \geq$ [mm]	90	110	130
	Minimum edge distance	c_{min} [mm]	45	55	65
for $s \geq$ [mm]		180	220	250	

Intermediate values for s_{min} and c_{min} by linear interpolation.

UPAT Anchor bolt MAX, MAX A4, MAX C	Annex B 3
Intended Use Minimum thickness, minimum spacings and edge distances	

Table B4: Minimum spacings and minimum edge distances of anchors according to **TR 020 and ETAG 001, Annex C** under **fire exposure** and according to **CEN/TS 1992-4: 2009, Annex D** under **fire exposure**

Type of anchor / size			MAX, MAX A4, MAX C						
			M8	M10	M12	M16	M20	M24	
Spacing	s_{min}	[mm]	35	40	45	60	95	100	
Edge distance	c_{min}	[mm]	$c_{min} = 2 \times h_{ef}$, for fire exposure from more than one side $c_{min} \geq 300$ mm						

Installation instructions

The fitness for use of the anchor can only be assumed if the anchor is installed as follows:

- Anchor installation carried out by appropriately qualified personnel and under the supervision of the person responsible for technical matters of the site.
- Use of the anchor only as supplied by the manufacturer without exchanging the components of the anchor
- Checking before placing the anchor to ensure that the strength class of the concrete in which the anchor is to be placed is in the range given and is not lower than that of the concrete to which the characteristic loads apply.
- Check of concrete being well compacted, e.g. without significant voids
- Edge distances and spacing not less than the specified values without minus tolerances.

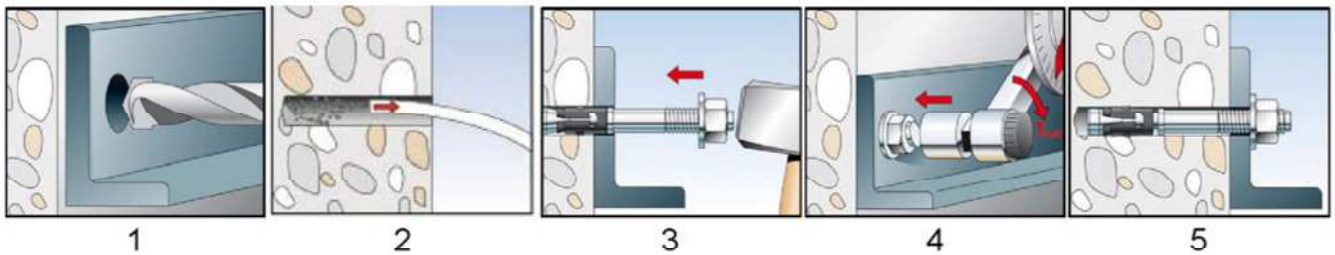

No.	Description	
1	Create drill hole	Drill hole perpendicular to concrete surface, positioning without damaging the reinforcement. In case of aborted hole: new drilling at a minimum distance away of twice the depth of the aborted hole or smaller distance if the aborted drill hole is filled with high strength mortar and if under shear or oblique tension load it is not in the direction of load application.
2	Clean bore hole	
3	Set anchor	
4	Expand anchor with prescribed installation torque T_{inst}	
5	Finished installation	

UPAT Anchor bolt MAX, MAX A4, MAX C

Intended Use
Minimum spacings and edge distances
Installation parameters

Annex B 4

Table C1: Characteristic values of **tension** resistance for **standard anchorage depth** under static and quasi-static action (Design method A, according to **ETAG 001, Annex C** or **CEN/TS 1992-4**)

Type of anchor / size			MAX, MAX A4, MAX C					
			M8	M10	M12	M16	M20	M24
Steel failure for standard anchorage depth								
Characteristic resistance	$N_{RK,s}$	[kN]	16,0	27,0	41,5	66,0	111,0	150,0
Partial safety factor	γ_{Ms}	³⁾	1,5					
Pullout failure for standard anchorage depth								
Effective anchorage depth	$h_{ef,sta} \geq$	[mm]	45	60	70	85	100	125
Characteristic resistance in cracked concrete C20/25	$N_{RK,p}$	[kN]	5	9	16	- ¹⁾		
Characteristic resistance in non - cracked concrete C20/25	$N_{RK,p}$	[kN]	9	16	25	- ¹⁾		
Increasing factors for $N_{RK,p}$ for cracked and non – cracked concrete	ψ_c	C25/30	1,10					
		C30/37	1,22					
		C35/45	1,34					
		C40/50	1,41					
		C45/55	1,48					
		C50/60	1,55					
Installation safety factor	$\gamma_2 = \gamma_{inst}$		1,0					
Concrete cone and splitting failure for standard anchorage depth in applications with concrete members of thickness $\geq 2x h_{ef}$								
Effective anchorage depth	h_{ef}	[mm]	45	60	70	85	100	125
Factor for non-cracked concrete	k_{ucr}	[-]	10,1					
Factor for cracked concrete	k_{cr}	[-]	7,2					
Min. thickness of concrete member	$h_{min,1}$	[mm]	100	120	140	170	200	250
Characteristic spacing	$s_{cr,N}$	[mm]	3 h_{ef}					
Characteristic edge distance	$c_{cr,N}$	[mm]	1,5 h_{ef}					
Spacing (splitting failure) ²⁾	$s_{cr,sp}$	[mm]	140	180	210	260	370	430
Edge distance (splitting failure) ²⁾	$c_{cr,sp}$	[mm]	70	90	105	130	185	215
Concrete cone and splitting failure for standard anchorage depth in applications with concrete members of thickness $< 2x h_{ef}$								
Effective anchorage depth	h_{ef}	[mm]	45	60	70	85	100	125
Factor for non-cracked concrete	k_{ucr}	[-]	10,1					
Factor for cracked concrete	k_{cr}	[-]	7,2					
Min. thickness of concrete member	$h_{min,2}$	[mm]	80	100	120	140	160	200
Characteristic spacing	$s_{cr,N}$	[mm]	3 h_{ef}					
Characteristic edge distance	$c_{cr,N}$	[mm]	1,5 h_{ef}					
Spacing (splitting failure) ²⁾	$s_{cr,sp}$	[mm]	180	240	280	340	480	550
Edge distance (splitting failure) ²⁾	$c_{cr,sp}$	[mm]	90	120	140	170	240	275

¹⁾ Pullout failure not relevant.

²⁾ Intermediate values for $s_{cr,sp}$ and $c_{cr,sp}$ between concrete thickness $h_{min,2}$ and $h_{min,1}$ by linear interpolation.

³⁾ In absence of other national regulations

UPAT Anchor bolt MAX, MAX A4, MAX C

Performances

Characteristic values of resistance under **tension** loads for **standard anchorage depth** (Design method A, according to **ETAG 001, Annex C** or **CEN/TS 1992-4**)

Annex C 1

Table C2: Characteristic values of **tension** resistance for **reduced anchorage depth** under static and quasi-static action (Design method A, according to **ETAG 001, Annex C** or **CEN/TS 1992-4:2009**)

Type of anchor / size		MAX, MAX A4, MAX C		
		M10	M12	M16
Steel failure for reduced anchorage depth				
Characteristic resistance	$N_{Rk,s}$ [kN]	27,0	41,5	66,0
Partial safety factor	$\gamma_{Ms}^{2)}$	1,5		
Pullout failure for reduced anchorage depth				
Effective anchorage depth	$h_{ef,red} \geq$ [mm]	40	50	65
Characteristic resistance in cracked concrete C20/25	$N_{Rk,p}$ [kN]	- ¹⁾		
Characteristic resistance in non - cracked concrete 20/25	$N_{Rk,p}$ [kN]	- ¹⁾		
Increasing factors for $N_{Rk,p}$ for cracked and non – cracked concrete	ψ_c	C25/30	1,10	
		C30/37	1,22	
		C35/45	1,34	
		C40/50	1,41	
		C45/55	1,48	
		C50/60	1,55	
Installation safety factor	$\gamma_2 = \gamma_{inst}$	1,0		
Concrete cone and splitting failure for reduced anchorage depth				
Effective anchorage depth	h_{ef} [mm]	40	50	65
Factor for non-cracked concrete	k_{ucr} [-]	10,1		
Factor for cracked concrete	k_{cr} [-]	7,2		
Min. thickness of concrete member	$h_{min,3}$ [mm]	80	100	140
Characteristic spacing	$s_{cr,N}$ [mm]	3 h_{ef}		
Characteristic edge distance	$c_{cr,N}$ [mm]	1,5 h_{ef}		
Spacing (splitting failure)	$s_{cr,sp}$ [mm]	160	200	260
Edge distance (splitting failure)	$c_{cr,sp}$ [mm]	80	100	130

¹⁾ Pullout failure not relevant.

²⁾ In absence of other national regulations

UPAT Anchor bolt MAX, MAX A4, MAX C

Performances

Characteristic values of resistance under **tension** for **reduced anchorage depth** (Design method A, according to **ETAG 001, Annex C** or **CEN/TS 1992-4:2009**)

Annex C 2

Table C3: Characteristic values of **shear** resistance for **standard and reduced anchorage depth** under static and quasi-static action (Design method A, according to **ETAG 001, Annex C** or **CEN/TS 1992-4:2009**)

Type of anchor / size	MAX, MAX A4, MAX C						
	M8	M10	M12	M16	M20	M24	
Steel failure without lever arm for standard and reduced anchorage depth							
Characteristic resistance	$V_{Rk,s}$ [kN]	12,0	20,0	29,5	55,0	70,0	86,0
Partial safety factor	γ_{Ms} ¹⁾	1,25					
Factor for ductility	k_2 [-]	1,0					
Standard anchorage depth							
Steel failure with lever arm							
Characteristic bending resistance	$M_{Rk,s}^0$ [Nm]	26	52	92	233	487	769
Partial safety factor	γ_{Ms} ¹⁾	1,25					
Factor for ductility	k_2 [-]	1,0					
Concrete pryout failure							
Factor k according to ETAG 001, Annex C or k_3 according to CEN/TS 1992-4	$k_{(3)}$	2,2		2,4	2,8		
Concrete edge failure							
Effective length of anchor in shear loading	l_f [mm]	45	60	70	85	100	125
Effective diameter of anchor	d_{nom} [mm]	8	10	12	16	20	24
Installation safety factor	$\gamma_2 = \gamma_{inst}$	1,0					
Reduced anchorage depth							
Steel failure with lever arm							
Characteristic bending resistance	$M_{Rk,s}^0$ [Nm]	-	40	89	171	-	-
Partial safety factor	γ_{Ms} ¹⁾	1,25					
Factor for ductility	k_2 [-]	1,0					
Concrete pryout failure							
Factor k according to ETAG 001, Annex C or k_3 according to CEN/TS 1992-4	$k_{(3)}$	-	2,0	2,3	-	-	
Concrete edge failure							
Effective length of anchor in shear loading	l_f [mm]	-	40	50	65	-	-
Effective diameter of anchor	d_{nom} [mm]	-	10	12	16	-	-

¹⁾ In absence of other national regulations

UPAT Anchor bolt MAX, MAX A4, MAX C

Performances

Characteristic values of resistance under **shear** loads
(Design method A, according to **ETAG 001, Annex C** or **CEN/TS 1992-4:2009**)

Annex C 3

Table C4: Characteristic values of **tension** resistance under **fire exposure** in cracked and non-cracked concrete for **standard and reduced anchorage depth** (Design according to TR 020 and ETAG 001, Annex C or CEN/TS 1992-4: 2009, Annex D)

Type of anchor / size MAX, MAX A4, MAX C	R30 Fire resistance 30 minutes			R60 Fire resistance 60 minutes		
	$N_{Rk,s,fi,30}$ [kN]	$N_{Rk,p,fi,30}$ [kN]	$N^0_{Rk,c,fi,30}$ [kN]	$N_{Rk,s,fi,60}$ [kN]	$N_{Rk,p,fi,60}$ [kN]	$N^0_{Rk,c,fi,60}$ [kN]
Standard anchorage depth						
M8	1,4	1,3	2,4	1,2	1,3	2,4
M10	2,8	2,3	5,0	2,3	2,3	5,0
M12	5,0	4,0	7,4	4,1	4,0	7,4
M16	9,4	7,1	12,0	7,7	7,1	12,0
M20	14,7	9,0	18,0	12,0	9,0	18,0
M24	21,1	12,6	31,4	17,3	12,6	31,4
Reduced anchorage depth						
M10	2,8	2,3	1,8	2,3	2,3	1,8
M12	5,0	3,2	3,2	4,1	3,2	3,2
M16	9,4	4,7	6,1	7,7	4,7	6,1
R90 Fire resistance 90 minutes						
	R90 Fire resistance 90 minutes			R120 Fire resistance 120 minutes		
	$N_{Rk,s,fi,90}$ [kN]	$N_{Rk,p,fi,90}$ [kN]	$N^0_{Rk,c,fi,90}$ [kN]	$N_{Rk,s,fi,120}$ [kN]	$N_{Rk,p,fi,120}$ [kN]	$N^0_{Rk,c,fi,120}$ [kN]
Standard anchorage depth						
M8	0,9	1,3	2,4	0,8	1,0	1,9
M10	1,9	2,3	5,0	1,6	1,8	4,0
M12	3,2	4,0	7,4	2,8	3,2	5,9
M16	6,0	7,1	12,0	5,2	5,6	9,6
M20	9,4	9,0	18,0	8,1	7,2	14,4
M24	13,5	12,6	31,4	11,6	10,1	25,1
Reduced anchorage depth						
M10	1,9	2,3	1,8	1,6	1,8	1,4
M12	3,2	3,2	3,2	2,8	2,5	2,5
M16	6,0	4,7	6,1	5,2	3,8	4,9

In absence of other national regulations the partial safety factor for resistance under fire exposure $\gamma_{M,fi} = 1,0$ is recommended.

UPAT Anchor bolt MAX, MAX A4, MAX C

Performances:

Characteristic values of resistance under **tension** loads and
(Design according to TR 020 and ETAG 001, Annex C or CEN/TS 1992-4: 2009, Annex D)

Annex C 4

Table C5: Characteristic values of **shear resistance under fire exposure** in cracked and non-cracked concrete for **standard and reduced anchorage depth** (Design according to **TR 020 and ETAG 001, Annex C** or **CEN/TS 1992-4:2009, Anhang D**)

Type of anchor / size MAX, MAX A4, MAX C	R30 Fire resistance 30 minutes			R60 Fire resistance 60 minutes		
	$V_{Rk,s,fi,30}$ [kN]	$M_{Rk,s,fi,30}^0$ [Nm]	k	$V_{Rk,s,fi,60}$ [kN]	$M_{Rk,s,fi,60}^0$ [Nm]	k
Standard anchorage depth						
M8	1,8	1,4	2,2	1,6	1,2	2,2
M10	3,6	3,6	2,2	2,9	3,0	2,2
M12	6,3	7,8	2,4	4,9	6,4	2,4
M16	11,7	19,9	2,8	9,1	16,3	2,8
M20	18,2	39,0	2,8	14,2	31,8	2,8
M24	26,3	67,3	2,8	20,5	55,0	2,8
Reduced anchorage depth						
M10	3,6	3,6	2,0	2,9	3,0	2,0
M12	6,3	7,8	2,3	4,9	6,4	2,3
M16	11,7	20,0	2,3	9,1	16,3	2,3
Standard anchorage depth						
R90 Fire resistance 90 minutes						
R120 Fire resistance 120 minutes						
	$V_{Rk,s,fi,90}$ [kN]	$M_{Rk,s,fi,90}^0$ [Nm]	k	$V_{Rk,s,fi,120}$ [kN]	$M_{Rk,s,fi,120}^0$ [Nm]	k
Standard anchorage depth						
M8	1,3	1,0	2,2	1,2	0,8	2,2
M10	2,2	2,4	2,2	1,9	2,1	2,2
M12	3,5	5,0	2,4	2,8	4,3	2,4
M16	6,6	12,6	2,8	5,3	11,0	2,8
M20	10,3	24,6	2,8	8,3	21,4	2,8
M24	14,8	42,6	2,8	11,9	37,0	2,8
Reduced anchorage depth						
M10	2,2	2,4	2,0	1,9	2,1	2,0
M12	3,5	5,0	2,3	2,8	4,3	2,3
M16	6,6	12,6	2,3	5,3	11,0	2,3

Concrete pryout failure: In Equation (5.6) of ETAG 001, Annex C, 5.2.3.3 the $k_{(3)}$ -factor of Table C3 and the relevant values of $N_{0Rk,c,fi}$ of Table C4 have to be considered.

Concrete edge failure: The characteristic resistance $V_{Rk,c,fi}^0$ in concrete C20/25 to C50/60 is determined by: $V_{Rk,c,fi}^0 = 0,25 \times V_{Rk,c}^0$ (R30, R60, R90), $V_{Rk,c,fi}^0 = 0,20 \times V_{Rk,c}^0$ (R120) with $V_{Rk,c}^0$ as initial value of the characteristic resistance in cracked concrete C20/25 under normal temperature according to ETAG 001, Annex C, 5.2.3.4.

In absence of other national regulations the partial safety factor for resistance under fire exposure $\gamma_{M,fi} = 1,0$ is recommended.

UPAT Anchor bolt MAX, MAX A4, MAX C

Annex C 5

Performances:

Characteristic values of resistance under **shear loads and fire exposure**
(Design according to **TR 020 and ETAG 001, Annex C** or **CEN/TS 1992-4:2009, Annex D**)

Table C6: Valid anchor sizes for seismic design, performance category C1, standard and reduced anchorage depth

Type of anchor / size		MAX, MAX A4, MAX C					
		M8	M10	M12	M16	M20	M24
Standard effective anchorage depth	$h_{ef,sta} \geq$ [mm]	45	60	70	85	100	125
Thickness of fixture	$t_{fix,min} =$ [mm]	0	0	0	0	0	0
	$t_{fix,max} =$ [mm]	100	100	120	160	250	300
Length of anchor	$L_{min} =$ [mm]	64,5	84,5	99	122	141	174
	$L_{max} =$ [mm]	167	186	221	284,5	394	477
Reduced effective anchorage depth	$h_{ef,red} \geq$ [mm]	-	40	50	65	-	-
Thickness of fixture	$t_{fix,min} =$ [mm]	-	0	0	0	-	-
	$t_{fix,max} =$ [mm]	-	120	140	180	-	-
Length of anchor	$L_{min} =$ [mm]	-	64,5	79	102	-	-
	$L_{max} =$ [mm]	-	186	221	284,5	-	-

Table C7: Valid anchor sizes for seismic design, performance category C2, standard and reduced anchorage depth

Type of anchor / size		MAX, MAX A4, MAX C ¹⁾					
		M8	M10	M12	M16	M20	M24
Standard effective anchorage depth	$h_{ef,sta} \geq$ [mm]	-	60	70	85	100	-
Thickness of fixture	$t_{fix,min} =$ [mm]	-	0	0	0	0	-
	$t_{fix,max} =$ [mm]	-	100	120	160	250	-
Length of anchor	$L_{min} =$ [mm]	-	84,5	99	122	141	-
	$L_{max} =$ [mm]	-	186	221	284,5	394	-
Reduced effective anchorage depth	$h_{ef,red} \geq$ [mm]	-	40	50	65	-	-
Thickness of fixture	$t_{fix,min} =$ [mm]	-	0	0	0	-	-
	$t_{fix,max} =$ [mm]	-	120	140	180	-	-
Length of anchor	$L_{min} =$ [mm]	-	64,5	79	102	-	-
	$L_{max} =$ [mm]	-	186	221	284,5	-	-

¹⁾ MAX C: Only valid for cold-formed version (see A1)

UPAT Anchor bolt MAX, MAX A4, MAX C

Performances:
Valid sizes in cracked concrete for seismic design

Annex C 6

Table C8: Characteristic values of **tension and shear** resistance for **standard- and reduced anchorage depth** under **seismic action**
(Design according to **TR 045: Performance category C1**)

Type of anchor / size	MAX, MAX A4, MAX C							
	M8	M10	M12	M16	M20	M24		
Steel failure for standard anchorage depth								
Characteristic resistance tension load C1	$\frac{h_{ef,sta}}{h_{ef,red.}}$	$N_{RK,s,C1}$ [kN]	16,0	27,0	41,0	66,0	111,0	150,0
			-				-	-
Partial safety factor	$\gamma_{Ms,C1}^{1)}$ [-]						1,5	
Pullout failure for standard anchorage depth								
Characteristic resistance tension load in cracked concrete C1	$\frac{h_{ef,sta}}{h_{ef,red.}}$	$N_{RK,p,C1}$ [kN]	4,6	8,0	16,0	28,2	36,0	50,3
			-				-	-
Installation safety factor	$\gamma_{2,C1}$ [-]						1,0	
Steel failure without lever arm for standard anchorage depth								
Characteristic resistance shear load C1	$\frac{h_{ef,sta}}{h_{ef,red.}}$	$V_{RK,s,C1}$ [kN]	11	17	27	47	56	69
			-				-	-
Partial safety factor	$\gamma_{Ms,C1}^{1)}$ [-]						1,25	

Table C9: Characteristic values of **tension and shear** resistance for **standard- and reduced anchorage depth** under **seismic action**
(Design according to **TR 045: Performance category C2**)

Type of anchor / size	MAX, MAX A4, MAX C ²⁾							
	M8	M10	M12	M16	M20	M24		
Steel failure for standard anchorage depth								
Characteristic resistance tension load C2	$\frac{h_{ef,sta}}{h_{ef,red.}}$	$N_{RK,s,C2}$ [kN]	-	27	41	66	111	-
							-	
Partial safety factor	$\gamma_{Ms,C2}^{1)}$ [-]						1,5	
Pullout failure for standard anchorage depth								
Characteristic resistance tension load in cracked concrete C2	$\frac{h_{ef,sta}}{h_{ef,red.}}$	$N_{RK,p,C2}$ [kN]	-	5,1	7,4	21,5	30,7	-
				2,7	4,4	16,4	-	
Installation safety factor	$\gamma_{2,C2}$ [-]						1,0	
Steel failure without lever arm for standard anchorage depth								
Characteristic resistance shear load C2	$\frac{h_{ef,sta}}{h_{ef,red.}}$	$V_{RK,s,C2}$ [kN]	-	10,0	17,4	27,5	39,9	-
				7,0	12,7	22,0	-	
Partial safety factor	$\gamma_{Ms,C2}^{1)}$ [-]						1,25	

¹⁾ In absence of other national regulations

²⁾ MAX C: Only valid for cold-formed version (see A1)

UPAT Anchor bolt MAX, MAX A4, MAX C

Performances:
Characteristic values of resistance under **tension and shear** loads under seismic action

Annex C 7

Table C10: Displacements due to tension loads for **standard and reduced anchorage depth**
(Design method A, according to **ETAG 001, Annex C** or **CEN/TS 1992-4:2009**)

Type of anchor / size			MAX, MAX A4, MAX C					
			M8	M10	M12	M16	M20	M24
Values for standard anchorage depth								
Tension load in cracked concrete	N	[kN]	2,3	4,2	7,5	13,2	16,4	22,9
Displacement	δ_{N0}	[mm]	0,5	0,5	0,7	1,0	1,2	1,2
	$\delta_{N\infty}$	[mm]	1,2				1,4	1,5
Tension load in non - cracked concrete	N	[kN]	4,2	7,5	11,7	18,7	23,3	32,5
Displacement	δ_{N0}	[mm]	0,3	0,3	0,5	0,7	1,2	1,2
	$\delta_{N\infty}$	[mm]	1,2				1,4	1,5
Values for reduced anchorage depth								
Tension load in cracked concrete	N	[kN]	-	4,2	6,0	9,0	-	-
Displacement	δ_{N0}	[mm]	-	0,5	0,7	1,0	-	-
	$\delta_{N\infty}$	[mm]	1,2				-	-
Tension load in non - cracked concrete	N	[kN]	-	5,7	8,5	12,6	-	-
Displacement	δ_{N0}	[mm]	-	0,3	0,5	0,7	-	-
	$\delta_{N\infty}$	[mm]	1,2				-	-

Table C11: Displacements due to shear loads for **standard and reduced anchorage depth**
(Design method A, according to **ETAG 001, Annex C** or **CEN/TS 1992-4:2009**)

Type of anchor / size			MAX, MAX A4, MAX C					
			M8	M10	M12	M16	M20	M24
Shear load in cracked and non-cracked concrete	V	[kN]	6,9	11,4	16,9	31,4	39,4	48,5
Displacement	δ_{V0}	[mm]	2,4	4,2	4,5	3,0	3,6	3,6
	$\delta_{V\infty}$	[mm]	3,6	6,3	6,8	4,5	5,4	5,4

UPAT Anchor bolt MAX, MAX A4, MAX C

Performances:
Displacements under **tension and shear** loads under seismic action

Annex C 8

Table C12: Displacements due to tension loads for **standard and reduced anchorage depth**
(Design according to **TR 045: Performance category C2**)

Type of anchor / size	MAX, MAX A4, MAX C						
	M8	M10	M12	M16	M20	M24	
Values for standard anchorage depth							
Displacement DLS	$\delta_{N,C2 (DLS)}$ [mm]	-	2,7	4,4	4,4	5,6	-
Displacement ULS	$\delta_{N,C2 (ULS)}$ [mm]	-	11,5	13,0	12,3	14,4	-
Values for reduced anchorage depth							
Displacement DLS	$\delta_{N,C2 (DLS)}$ [mm]	-	2,7	4,4	4,4	-	-
Displacement ULS	$\delta_{N,C2 (ULS)}$ [mm]	-	11,5	13,0	12,3	-	-

Table C13: Displacements due to shear loads for **standard and reduced anchorage depth**
(Design according to **TR 045: Performance category C2**)

Type of anchor / size	MAX, MAX A4, MAX C						
	M8	M10	M12	M16	M20	M24	
Values for standard anchorage depth							
Displacement DLS	$\delta_{V,C2 (DLS)}$ [mm]	-	4,1	4,4	4,3	4,8	-
Displacement ULS	$\delta_{V,C2 (ULS)}$ [mm]	-	6,2	7,8	8,1	11,2	-
Values for reduced anchorage depth							
Displacement DLS	$\delta_{V,C2 (DLS)}$ [mm]	-	3,6	4,7	5,5	-	-
Displacement ULS	$\delta_{V,C2 (ULS)}$ [mm]	-	5,0	7,5	10,1	-	-

UPAT Anchor bolt MAX, MAX A4, MAX C

Performances:
Displacements under **tension and shear** loads under seismic action

Annex C 9